



Operating Instructions Pump Series

**2876.00
2876.01
2876.02
2876.03**



© by Scherzinger Pumpen GmbH & Co. KG

Version: 1.0.0 English

**Date: 7/8/2021
Author: Scherzinger C.**

Release: King T.



© by Scherzinger Pumpen GmbH & Co. KG

The copyright to this document shall remain with **Scherzinger Pumpen GmbH & Co. KG**, 78120 Furtwangen / Deutschland.

The contents of this documentation (texts, illustrations, diagrams, graphics, plans etc.) may not, in whole or in part, be redistributed, reproduced, used for unauthorized competitive purposes or made available to third parties without our express written consent.

Scherzinger Pumpen GmbH & Co. KG

Bregstraße 23 - 25
78120 Furtwangen / Deutschland

Telephone: +49 7723 6506-0

E-mail: info@scherzinger.de

Internet: www.scherzinger.de

Manual: Operating Instructions

Edition: 1.0.0 English

Issue date: 7/8/2021

We reserve the right to make changes to the product and design in the interests of product improvement.

Table of contents

1	Introduction	5
1.1	Preface	5
1.2	Product Identification/Product Information/duktinformation	5
1.3	Storage	5
1.4	Definition of Terms	5
1.5	Offices Abroad	5
1.6	Symbols used in this Manual	6
1.6.1	Levels of Danger	6
1.6.2	Danger Symbols	7
1.6.3	Command Symbols	8
1.6.4	General Symbols	9
1.7	Personal Protective Equipment	9
1.8	Definition of Qualified/ Authorized Personnel	9
1.9	Obligations of the Operator	10
1.10	Obligations of the Personnel	11
1.11	Identification Based on the Example of the Pump Type 2876.00	12
1.12	Intended Use/Normal Operation	12
1.12.1	Limit Values	13
1.12.2	Pin Assignment	14
1.12.3	Overview of Series/Medium-affected Parts	14
1.12.4	Limitation of use	15
1.13	Improper Use/Fault	16
1.13.1	Danger from Dust	17
1.13.2	Danger from Dry Running of the Pump	17
1.13.3	Danger from Overheating of the Pump	17
1.13.4	Danger from Overpressure in the Pump	18
1.13.5	Danger from Particles/Foreign Matter in the Fluid	18
1.13.6	Danger from Incorrect Direction of Rotation	19
1.14	Complaints	19
1.15	Warranty and Liability	20
1.16	Declaration of Conformity	21
1.16.1	Declaration of conformity as per directive 2006/42/EC (Machinery Directive)	21
1.17	Certificate of Non-objection	22
2	Safety Instructions	23
2.1	Danger from Hot Parts	23
2.2	Danger from Electric Shock	24
2.3	Danger from Magnetic Fields	24
2.4	Danger from Fluids	25
2.5	Danger from Pump Weight	25
3	Transport and Interim Storage	26
3.1	Shipping of the Pump and Protective Measures	26
3.2	Interim Storage	26
3.3	Conserving the Machine for Storage After Operating/Flushing the Pump.	26
3.4	Return to the Factory	27
4	Mode of Operation/Functional Description	28
4.1	Pump Function	28
4.2	Constructive Design of the Pump	28
5	Installation / Dismantling	29
5.1	Information about the Installation Location	29
5.2	First Installation	29
5.3	Installation Position	30

5.4	Connection Pipes	30
6	Commissioning/Decommissioning	32
6.1	Requirement for Commissioning	32
6.2	Commissioning	32
6.3	Decommissioning	32
6.4	Removal from the System	33
7	Maintenance/Cleaning	34
7.1	General Information	34
7.2	Safety Instructions for Maintenance, Inspection and Installation work	34
7.3	Maintenance Cycle	35
7.4	External Cleaning of the Pump	35
7.5	Cleaning of the Pump for Use in Special Areas	35
8	Faults, Causes and Rectification	36
9	Technical Data	38
9.1	Connection Dimensions 2876.00 / 2876.02	38
9.2	Connection Dimensions 2876.01 / 2876.03	38
9.3	Sound Pressure Level	39
9.4	Non-ionizing Radiation	39
10	Disposal	40
10.1	Disposal of the Fluid	40
11	Appendix	41
11.1	List of Revisions	41
11.2	Signature List	42

1 Introduction

1.1 Preface

These operating instructions of the company **Scherzinger Pumpen GmbH & Co. KG** are part of the product (Pump).

The operating instructions are intended for everyone who undertakes assembly, installation, commissioning, and service work on the product (Pump).

Please read the operating instructions carefully, taking particular note of the safety instructions!

Should you have any questions with regards to the product (Pump) its application range or in case of any other questions, our employees be available for assistance.

1.2 Product Identification/Product Information/Produktinformation

Validity

The descriptions in these operating instructions refer exclusively to the product (Pump), as described in the technical data (⇒ chapter "[Technical Data](#)"³⁸) and as developed and built by the manufacturer.

Product Information

The product (Pump) from Scherzinger Pumpen GmbH & Co. KG is suited for pumping liquids. That which do not have a corrosive or aggressive effect on the materials used (⇒ chapter "[Medium-affected Parts](#)"¹⁴).

1.3 Storage

These **operating instructions** must always be close to the product (Pump) and be within easy reach when needed.

1.4 Definition of Terms

In the following section, any type of fluid to be transported will be referred to as "**fluid**".

These operating instructions are valid for the following pump series:

2876.00
2876.01
2876.02
2876.03

To make things clearer, the series **2876.00**; **2876.01**; **2876.02** and **2876.03** are identified below as **2876**.

The **2876** pump series are available as compact unit.

The exact design of your pump is specified / included in your order documentation.

1.5 Offices Abroad

A list of our worldwide offices, including addresses, can be obtained from the manufacturer's factory or found online at www.scherzinger.de.

In most instances, these offices are sales branches which, to certain extent, also carry out repair and maintenance work. However, this work is preferentially carried out in the main plant in Furtwangen.

1.6 Symbols used in this Manual

1.6.1 Levels of Danger



DANGER!

Texts labelled with DANGER! warn of exceptionally great and acute hazards. These hazards will inevitably result in serious (irreversible) injuries or even death if no preventative countermeasures are taken!

It is imperative that these texts are taken note of and preventative countermeasures are taken!



WARNING!

Texts labelled with WARNING! warn of exceptionally great and potential hazards. These hazards will inevitably result in serious (irreversible) injuries or even death if no preventative countermeasures are taken!

It is imperative that these texts are taken note of and preventative countermeasures are taken!



CAUTION!

Texts labelled with CAUTION! warn of potentially dangerous situations. These situations will inevitably result in slight to moderate (irreversible) injuries if no preventative countermeasures are taken!

It is imperative that these texts are taken note of and preventative countermeasures are taken!

ATTENTION!

Texts labeled with ATTENTION! contain important notes about situations which, if the preventative countermeasures are not taken, could possibly damage the product and/or its functions or materials located in its immediate vicinity.

It is imperative that these texts are taken note of and preventative countermeasures are taken!



Texts labeled with this symbol contain very important instructions!

It is imperative that these texts are taken note of!



This symbol indicates texts which contain important instructions/comments or tips.

1.6.2 Danger Symbols

1.6.2.1 General Danger Symbol



Warning of dangers that result in serious (irreversible) injuries or even death!

1.6.2.2 Specific Danger Symbols



Warning of dangerously hot surfaces!



Warning of mechanical movements or risk of hand injuries!



Warning of flammable substances!



Warning of incorrect direction of rotation!



Warning of moving machine!

1.6.3 Command Symbols



Take note of the documentation and information provided!



Switch off release the pump!



Wear hearing protection!



Wear safety gloves for protection against thermal risks as per EN 407!



Wear protection class 1 safety shoes!



Wear respiratory protection!



Wear safety glasses!

1.6.4 General Symbols

- This dot indicates the description of activities that are to be performed.
- This dash indicates numerations.
- ⇒ This arrow indicates cross-references.
For purposes of clarity, abbreviations are used for cross-references made to other chapters in the text, e.g.:
(⇒ chapter "[Offices Abroad](#)"⁵ ")
This means: Refer to page **6**, chapter **Offices Abroad** in these operating instruktion.
- (3) Numbers in parentheses refer to positions within the figures.

1.7 Personal Protective Equipment

The personal protective equipment suggested in these operating instructions only applies to this particular product (Pump).

The requirements for personal protective equipment arising from local environmental conditions, the fluid, other products, or the (combined) usage with other products are not described in these operating instructions and must be adapted to the actual risks by the operator.



The actual definition of personal protective equipment depends on the fluid being transported and the cleaning agent used. It must be specified by the operator!

1.8 Definition of Qualified/ Authorized Personnel

Bodily injury or material damage may result from unqualified operations of the product (Pump). For this reason, only qualified personnel may operate the product (Pump), commission and decommission it, clean and maintain it.

In this sense, qualified personnel are persons who:

- are familiar with the safety concepts of the product (Pump).
- are trained as operating personnel assigned to the handling of the product (Pump) and who are familiar with the contents of the operating instructions regarding operation.
- have received appropriate instruction from qualified personnel.
- have received authorization from the supervisor responsible for the safety of the product (Pump) to perform the necessary activities because of their education, experience and training as well as knowledge of applicable standards, provisions, accident prevention regulations, explosion protection and operating conditions, and are able to recognize and prevent potential hazards.

1.9 Obligations of the Operator

The operator undertakes to only let experts work with this product (Pump) who

- have been sufficiently trained to perform the activities in question;
- are acquainted with the fundamental regulations on safety and accident prevention in the workplace and have received qualified instruction for the handling of the product (Pump);
- have read and understood the safety and warning instructions contained in these operating instructions.

In the interests of all these involved, please take note of the following instructions:

- In addition to these operating instructions, please make available all generally valid statutory and other relevant binding regulations regarding safety and accident prevention in the workplace, environmental protection and instruct the personnel who will be working with the product (Pump) according to these regulations!
- In addition to these operating instructions, please make available instructions regarding operational particularities such as those related to work organization, workflows, authorized personnel (including obligatory supervision and registration)!
- Clearly establish the specific responsibilities of the personnel for operation, cleaning, maintenance, etc.!
- Ensure that the personnel are working in a safety- and risk-conscious manner by checking in regular intervals!
- Implement measures that ensure that the product (Pump) is only operated in a safe and fully functional condition!
- Have the product (Pump) cleaned and serviced in the specified intervals (⇒ **chapter "Maintenance / Cleaning"**!)
- Do not make any structural changes (excluding those described in the operating instructions) without prior written consent from the manufacturer!
- Implement stringent provisions to ensure that personnel that has not been instructed on the basis of the safety instructions and the residual risks which may arise when working on or with the product (Pump), do not enter the hazard area of the product (Pump)!
- When surface temperatures exceed 50 °C (122 °F), a warning sign must be placed on the machine in a clearly visible position. When surface temperatures exceed 80°C (176 °F), insulation will be required, or the area must be enclosed/demarcated at an adequate distance from the source of danger.
- Securing the working environment is solely the operator's responsibility.

1.10 Obligations of the Personnel

All persons authorized to work with the product (Pump) are obliged, before commencing work to

- observe the fundamental regulations on safety and accident prevention at the workplace;
- read the safety and warning instructions in this documentation.

In the interests of all these involved, please take note of the following instructions:

- Do not carry out any work that is questionable in terms of safety!
 - Observe all hazard and warning signs in these operating instructions!
 - In addition to these operating instructions, comply with the generally valid statutory and other relevant binding regulations regarding safety and accident prevention in the workplace and environmental protection!
 - Be aware of available fire detection and fire-fighting equipment, locate fire extinguishers and find out how to operate them!
 - Wear adequate (personal) protective equipment suitable for the work you have to carry out!
 - Tie back and secure any long hair. Do not wear loose clothing or jewelry (including rings)!
 - Only perform tasks for which you have received the appropriate training!
 - Do not carry out any repair work without contacting the manufacturer and an authorized representative of the operating company first!
 - Do not make any structural changes (with the exception of those described in the operating instructions) without prior written consent from the manufacturer!
 - Take steps to ensure that other people, who are not working on the pump and therefore do not know the potential risks of the pump, cannot access the hazard areas of the machine.
 - In the event of a safety hazard, decommission the pump! Secure the pump against being accidentally switched back on and notify the operator immediately!
-



1.11 Identification Based on the Example of the Pump Type 2876.00



Abb. 1: Type plate for pump with motor.

1.12 Intended Use/Normal Operation

The sole use of the product (Pump) defined in the technical data is the transportation of low to medium viscous particle-free media with degreasing to well-lubricating characteristics, that do not have a corrosive or aggressive effect on the product material (Pump). It is suitable for the transportation of alkaline as well as acid fluids.

The product (Pump) is exclusively intended

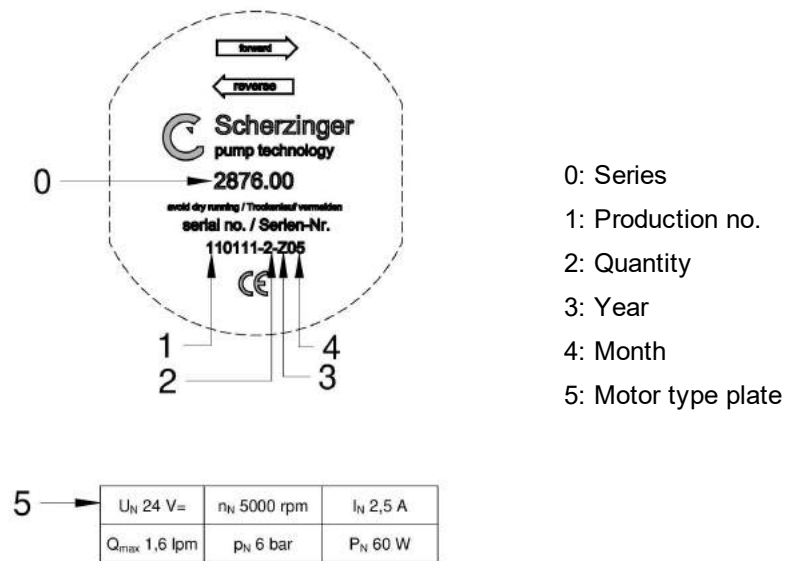
- for use within permanent buildings,
- for commercial use,
- for transporting fluids,
- for use by authorized personnel with a minimum age of 16 years.

The operator as well as the operating maintenance and repair personnel are required to have an adequate understanding of one official language.

The product (Pump) is not designed for use in a radioactive or biologically contaminated atmosphere and fluids!

The components/wear parts to be used must have been approved by the manufacturer for their intended purpose.

1.12.1 Limit Values

Intended use can be ensured by observing the following limit values:

Beschreibung		Wert
Swallowing volume		0,32 cm ³ /U
Differential pressure		10 bar, nominal 7 bar
max. Intel pressure		15 bar
Burst pressure		>30 bar
max. Flow rate		96 l/h (1,6 l/min)
Suction height (wet)		max. 4,0 m
Operating life		>10.000 h
Required filter mesh		min. 20 µm, β = 200
Ambient temperature		-30° - 85°
Liquid temperature		-10° - 80°C
Sound pressure level		< 70 dB(A) determined at: Rotation speed: 2800 1/min Operating pressure: 10 bar Operating temperature: 20 °C Fluid: 1 mm ² /s, non-lubricating (⇒ Chapter Sound Pressure Level ³⁹)
Dimensions		observe the corresponding data sheets (⇒ Chapter Technische Daten ³⁸)
Drive	Motor Supply voltage Power consumption Control	BLDC 24V DC max. 50W 2Q control

The limit values listed are only guidelines. The actual limit values depend on the application. Influencing factors are, for example, the viscosity and the type of medium to be pumped.

Any other use beyond the intended use described in the operating instructions is deemed improper

1.12.2 Pin Assignment

Signal		Signature	Colour
Supply voltage		24V \pm 2V	Red
Gound		0 V	Black
Speed control		1 - 3,4 V for 600 - 5.500 1/min	White
Sens of rotation	0 V 24V	Reverse Forward	Brown
Speed feedback		<0,8V low, >2V high, rectangle, 3 revolutions per minute	Green

1.12.3 Overview of Series/Medium-affected Parts

For the 2876.00 / 2876.01 / 2876.02 / 2876.03 series

Casing	1.4404
Cover	1.4404
Containment can with centering ring	1.4404
Shafts	1.4571
Drive gears	PEEK
bearings	PEEK
Sealing	FKM (alt. EPDM)
Fluid	Note the resistance of the materials mentioned above.

1.12.4 Limitation of use

Max. Possible flow rate

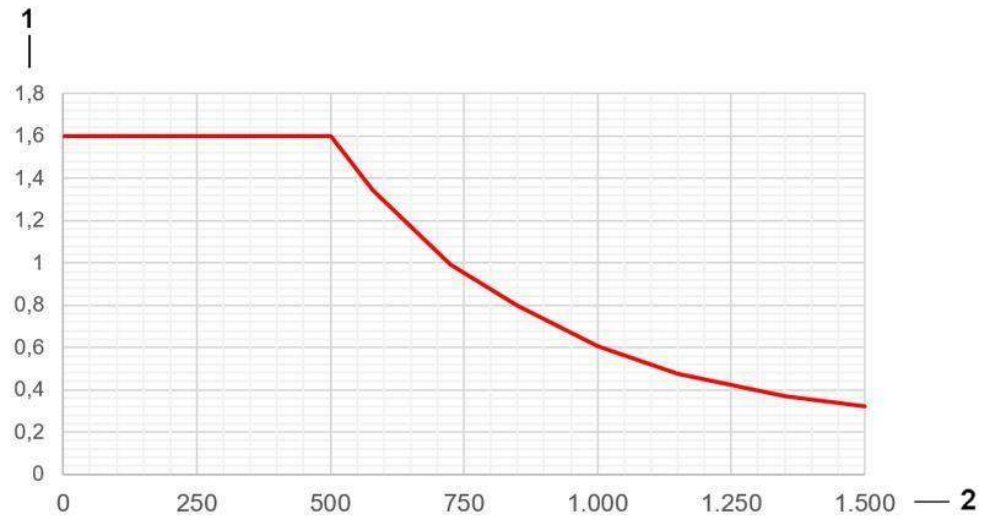

- 1 Max. Possible flow rate (l/min)
- 2 Viscosity (mPas)

Abb. 2: Max. Possible flow rate

Flow rate

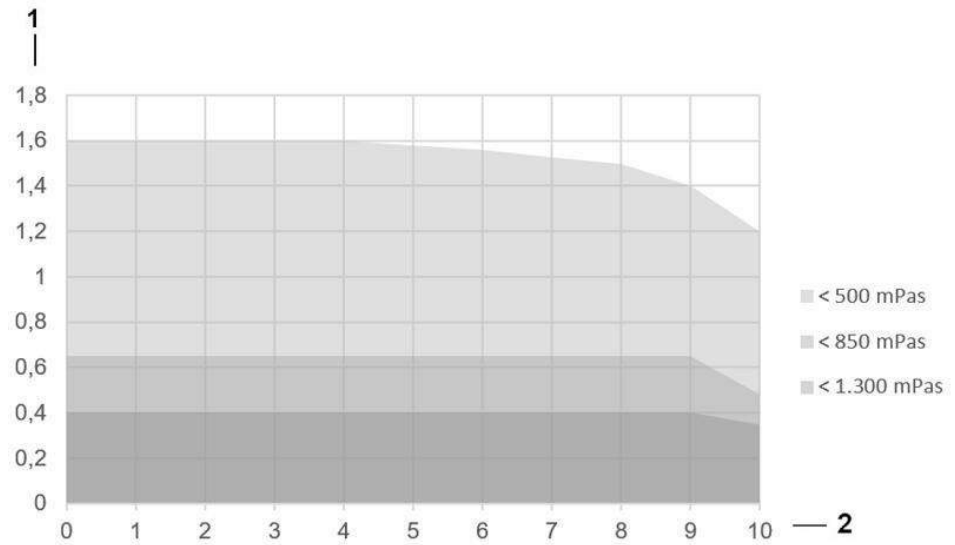

- 1. Possible flow rate (l/min)
- 2. Differential pressure (bar)

Abb. 3: Flow rate



DANGER!

If one or more limit values described in this section are exceeded, you must ask the manufacturer's plant if these operating conditions are authorized by the manufacturer. Otherwise, a modification of the pump that is adapted to your case must be carried out, because the pump or the system in which the pump is integrated can be damaged or destroyed and present a danger for personnel.

1.13 Improper Use/Fault

Deviations from normal operation are to be defined as faults.

Predictable faults can be defined as follows:

- Partial or complete dry running (caused by e.g. closed fittings, clogged filters ...)
- Large impurities in the fluid ($>50\mu\text{m}$) (such as beads of sweat, deposits from tanks, sediments ...)
- Incorrect direction of rotation
- Pressure overload (caused by e.g. closed fittings, faulty components ...)

There must not be any ferritic components in the fluid when operating the pump.

ATTENTION!

If improper use cannot be ruled out with certainty, the operator must put appropriate monitoring measures in place.

1.13.1 Danger from Dust



DANGER!

When operating the pump in a dusty environment, the danger of overheating and spontaneous ignition arises.

- *Protect the pump from dust using appropriate measures. Make sure that the air circulation is sufficient in order to avoid overheating of the pump.*
- *Remove dust deposits from the pump surface, the drive and the connection pipes on a regular basis in order to avoid the creation of ignition sources. The cleaning interval is determined by the amount of dustfall.*
- *Clean the pump as described in (⇒ chapter "[External Cleaning of the Pump](#)"³⁵). Take note of the manufacturer's specifications!*

1.13.2 Danger from Dry Running of the Pump



DANGER!

Without fluid, the product (Pump) runs dry. As the sliding surfaces are not lubricated, the drive gears and bearing bushes become hot and are thermally and mechanically destroyed.

If there is no fluid in the containment can, the heat induced by eddy current losses can also not be dissipated, resulting in the overheating of the pump.

On the suction side, the fluid to be transported must always be present in order to avoid temperature rises above the maximum permissible temperature (⇒ chapter "[Limit Values](#)"¹³).



Dry running protection

When the pump is being operated, the interior of the pump must always be filled with fluid. If this cannot be ensured by the operator, we recommend appropriate monitoring measures:

- level switch in the container or the feed pipe,
- flow monitor at the pump inlet,
- monitoring of the drive performance,
- TARGET/ACTUAL comparison at the pump output.

1.13.3 Danger from Overheating of the Pump



DANGER!

Overload, overheating or non-observance of normal operation can lead to an inadmissibly high temperature rise.

1.13.4 Danger from Overpressure in the Pump



DANGER!

An operation with closed shut-off devices suction/pressure pipe is not permitted! Due to closed shut-off devices or closed pipes, there is the risk of very high surface temperatures, after even a short period of time, caused by fluid overheating in the interior of the pump.



Overpressure protection

We recommend the following monitoring measures

- overflow valve
- pressure switch
- drive performance monitoring
- temperature monitoring

If the pump is operated against a closed system, the pump will heat up.

1.13.5 Danger from Particles/Foreign Matter in the Fluid



DANGER!

Inadmissible operating conditions can arise from foreign matters in the fluid and result in the premature wear of pump components.



Prefilter

We recommend the following monitoring measures:

- Filter with contamination indicator.
- Filter with negative pressure and differential pressure monitoring.

1.13.6 Danger from Incorrect Direction of Rotation



DANGER!

Operating the pump in the opposite direction of rotation can result in the increase of the resistance on the suction side.

The counter-pressure cannot be relieved. The pump performance is therefore converted to heat. In addition, the medium on the pressure side can be sucked out with the risk of dry running (⇒ chapter "[Danger from Dry Running of the Pump](#)"¹⁷) and a vacuum creation on the pressure side.

In both cases, there is a danger of an inadmissible heating of the pump. Furthermore, both the built-in sensors and the filter unit can be irreversibly damaged or destroyed.

The direction of rotation is marked on the pump and the connections on the system.

1.14 Complaints

Claims for damages relating to transport damages can only be asserted if the manufacturer and the delivery company are notified of the damage immediately.

- In case of returns (due to transport damages/repairs) please immediately write a damage protocol and send the parts back to the manufacturer's factory in the original packaging, if possible.
- Note down any transport damage on the shipping documents upon receipt of the goods!
- Include the following information with the return:
 - name and address of the sender and recipient,
 - type and serial number of the product (Pump),
 - description of the fault,
 - in case of transport damage: name of the delivery company and, if possible, the delivery date, name of the driver and registration number of the delivery vehicle,
 - certificate of non-objection.

1.15 Warranty and Liability

Our **General Terms and Conditions and Delivery Terms and Conditions** generally apply for the use of our product (Pump).

Deviating agreements must be made in writing and confirmed by us!

Our General Terms and Conditions and Delivery Terms and Conditions are sent to the operator with the offer.

Warranty and liability claims in case of personal injury or material damage are excluded if they are due to one or several of the following causes:

- Improper use of the product (Pump).
- Operation of the product (Pump) despite faulty safety devices or improperly installed or non-functioning protection and/or safety equipment.
- Failure to observe the instructions in these operating instructions concerning to security, transport, storage, installation, commissioning, operation, maintenance and repair of the product (Pump).
- Incorrect installation, commissioning, operation, maintenance and repair of the product (Pump).
- Inadequate monitoring and maintenance of parts subject to wear.
- Unauthorized modifications to the product (Pump).
- Major emergencies caused by the influence of foreign bodies or force majeure.

Only the manufacturer's original spare parts may be used to ensure functional reliability.

1.16 Declaration of Conformity

1.16.1 Declaration of conformity as per directive 2006/42/EC (Machinery Directive)

Declaration of conformity as per directive 2006/42/EC

In accordance with EC directive 2006/42/EC, appendix II A, dated 17 May, 2006, the manufacturer declares:

**Scherzinger Pumpen GmbH & Co. KG
Bregstraße 23 - 25
78120 Furtwangen / Deutschland**

that the product:

Pump

**2876.00
2876.01
2876.02
2876.03**

is supplied with an electric drive unit and therefore complies with the provisions of directive 2006/42/EC, appendix I, no.1.

The following harmonized standards were applied:

**EN ISO 12100:2011
EN 809:1998+A1:2009 + AC:2010
EN 60204-1:2019**

The following directives were applied:

Directive 2006/42/EC



Applied national technical standards and specifications:

Accident prevention regulations

Person responsible for documentation: Matthias Derse
Furtwangen, Thursday, July 8, 2021



Dipl.-Ing., MBA Matthias Derse
Managing Director

1.17 Certificate of Non-objection

The pump and its accessories, sent by us for inspection or repair, together with this certificate of non-objection,

Type Pump number Delivery date

Operating data:

Temperature: (°C) Viscosity: (mm²/s) Pressure: (bar) Fluid: _____

Reason for the repair order

Reason (continued)

- was not operated with hazardous fluids
- come into contact with fluids subject to labeling requirements or fluids containing harmful substances.

Specify the last fluid used

The pump has been carefully drained before shipping/hand-over and cleaned on the inside and the outside. The cleaning was performed in line with the relevant operating instructions.

- Specific safety measures are not necessary for further handling
- The following safety measures regarding flushing agents and disposal are necessary:

We guarantee that the above indications are correct and complete and that the pump has been shipped in accordance with the statutory requirements.

Company Name

Street Position

City Telephone

Country Fax

Date Company stamp/signature

For safety reasons, pumps that are delivered without the completed safety data sheet cannot be inspected nor repaired.

2 Safety Instructions

The pump is a quality product manufactured according to the accepted rules of technology. The pump left the manufacturer's factory in a technically and operationally safe condition!

However residual risks are present:

- during assembly/dismantling,
- during commissioning/decommissioning,
- during operation and
- during maintenance/cleaning.

If

- you are not aware of these residual risks,
- you fail to follow the warning messages in these operating instructions,
- you carry out work incorrectly,
- you use the pump for purposes other than the intended purpose,

these residual risks may lead to death, serious personal injury, or damage to product!

Due to these latent residual risks, the manufacturer is obliged to notify the operator and user about these risks!

We, the manufacturer, meet this obligation to instruct by providing the descriptions included in these operating instructions generally and, in particular, by providing the descriptions included in this chapter.

2.1 Danger from Hot Parts



DANGER!

- *If the pump is operated in a closed casing, it must be ensured that the casing does not overheat!*
- *We recommend the installation of a temperature sensor for automatic monitoring.*
- *If danger from hot parts arises, you have to protect these parts from being touched by means of a protective construction.*

2.2 Danger from Electric Shock



DANGER!

- *In case of faults in the electrical power supply, immediately switch off the pump or disconnect the pump from the power supply!*
- *Check the electrical equipment of the pump on a regular basis! In the case of faults in the electrical equipment, immediately switch off the pump! Have loose connections and burned/damaged cables replaced immediately!*
- *Secure the pump against re-commissioning.*

Five safety rules prior to starting work:

- *releasing*
- *securing against restarting*
- *determining voltage-free state*
- *earthing and shorting out*
- *covering or locking adjoining live parts*

2.3 Danger from Magnetic Fields



DANGER!

The magnetic coupling contains permanent magnets. Danger for people with active or passive implants can arise from the magnetic field!

- *People with pacemakers as well as those with active or passive implants may not enter into the area of the magnetic field. A safety distance of 25 cm should be observed from unfitted individual clutch parts. A minimum safety distance of 10 cm applies to fitted clutches with magnetic rotors aligned axially to one another and the surrounding clutch housing (pump carrier).*
- *Do not enter into the sphere of the magnetic field with electronic data carriers or devices.*
- *Do not place any ferromagnetic tools onto the axes or in proximity of the permanent magnetic field.*
- *Make sure that no ferromagnetic parts are attracted by the magnetic coupling and that they maintain a safety distance of at least 15 cm.*

2.4 Danger from Fluids

DANGER!

The conveyed fluids can cause injury, poisoning and danger to life.

- *When working on the pump, personal protective equipment must be worn.*

The definition of protective equipment is, amongst other things, dependent on the fluid and must therefore be newly determined for every application by the operator and made available for the personnel.

Dangerous fluids are:

- *flammable fluids*
- *corrosive fluids*
- *toxic fluids*
- *irritating fluids*
- *fluids hazardous to health*
- *carcinogenic fluids*
- *hot fluids*
- *cold fluids*



2.5 Danger from Pump Weight

CAUTION!

- *The 2876 Pump with three-phase motor has a total weight of over 1.1 kg. Therefore, it is important to ensure that the pump does not fall down when it is lifted. If the pump falls, there is a risk that a limb may be crushed and injured. It is therefore necessary to wear safety equipment.*

- *If carrying the pump cannot be prevented, make sure to always use both hands!*



3 Transport and Interim Storage

3.1 Shipping of the Pump and Protective Measures

The pump is shipped out of the factory with adequate protection against knocks and impacts. The inlet and outlet ports are sealed with protective plugs.

This measure is required in order to avoid the leakage of residual fluids that still remain in the pump head as result of a test run.

This also provides protection to the connecting threads. This is reliable protection against the ingress of foreign matter into the interior of the machine.

After having received the pump, you must immediately check the pump for transport damages. If you detect any damage, you must inform the responsible forwarder of this and Scherzinger Pumpen GmbH & Co. KG, 78120 Furtwangen / Deutschland.

3.2 Interim Storage

Follow these instructions when storing the pump:

- Do not store the pump in wet or damp rooms.
- Leave the protective plugs in, or place them in position.
- When storing for longer than six months, take anti-corrosion measures for the bare metal parts.
- The storage rooms must not contain any ozone-producing equipment, e.g. fluorescent light sources, mercury vapor lamps or electrical high-voltage equipment.
- Make sure that no condensation can occur. Relative humidity must be less than 65%.
- When storing the pump, make sure that the storage temperature is not below 5°C and does not exceed 50°C.

3.3 Conserving the Machine for Storage After Operating/Flushing the Pump.

Depending on the transported fluid, the pump must be prepared differently for storage. If no toxic or aggressive fluids were transported, flush the pump briefly with water without a differential pressure rise at a low speed.

ATTENTION!

- *When transporting dangerous or aggressive fluids, clean the pump in a way that any possible subsequent maintenance work can be carried out without endangering the health of the personnel.*
- *Flush the pump at middle speed with a neutralizing medium. Disassemble and manually clean those parts that were not completely cleaned by flushing.*

The conveying of curing mediums (e.g. varnishes) is not permitted



DANGER!

Danger of acid burns and explosion in case of reactions between the transported fluid and the flushing/cleaning agent used. When flushing the pump, the flushing/cleaning agent must be adapted to the fluid last transported by the machine to rule out a potentially hazardous chemical reaction between the transported fluid and the flushing/cleaning agent.

3.4 Return to the Factory

If you choose to return the pump to the manufacturer's factory for repair or maintenance, please fill in the certificate of non-objection (⇒chapter "[Certificate on Non-objection](#)"²²) completely and enclose it. The repair cannot be carried out without this certificate!

4 Mode of Operation/Functional Description

4.1 Pump Function

The pump performance of a gear pump is generated by the opposed rotation of two gears in a pump casing.

The gears are fixed to two shafts that are positioned in the pump casing and on the pump cover. One of the two gears is driven by a shaft, the second gear is picked up via the gear meshing.

The spaces opening between the gears create a vacuum that sucks the fluid into the pump and transports it between the spaces between the gears and the casing wall.

In the area where the gears mesh, the fluid is pressed out of the spaces into the outlet. By this means, the fluid can also be transported against overpressure.



Abb. 4: Functional principle of the gear pump

4.2 Constructive Design of the Pump

The pump has a compact design. In contrast to conventional gear pumps, the magnetic coupling, motor and motor controller merge with each other. This results in a very compact, yet very reliable execution. The pump has a liquid inlet and an outlet that can be configured with G 1/8" or with hose connection, depending on the customer's requirements. All bearings, both from the pump as well as the motor, are lubricated and flushed with the medium. You should therefore pay attention to the particle purity and the resistance of the pump materials. The space of the motor rotor is also washed around by the conveyed medium to achieve a cooling effect. The Motor windings as well as the motor electronics are separated by a stainless steel partition from the conveyed medium. The motor and electronics are encapsulated by a casing and a cable bushing, which provide a protection to the environment according to IP 55.

5 Installation / Dismantling

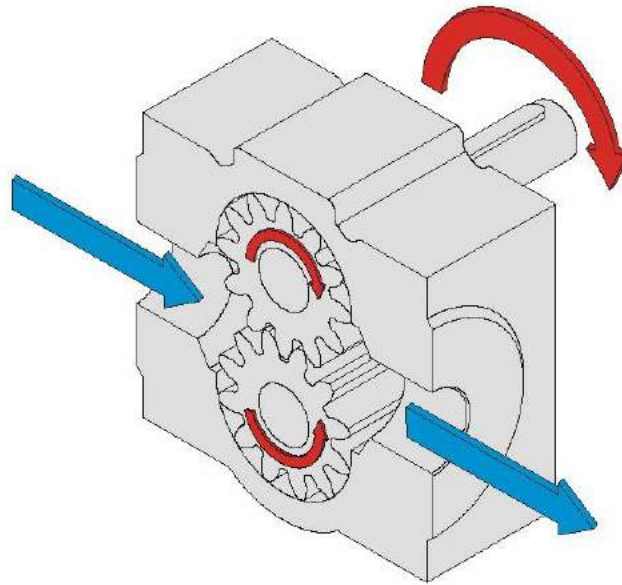
5.1 Information about the Installation Location



ATTENTION!

When selecting a location, make sure that there is enough space for maintenance and repair work. You have to be able to install and dismantle the pump without problems.

5.2 First Installation

- First, visually check the pump supplied by us for transport damages (⇒Chapter "[Complaints](#)"¹⁹)
- Using the following points, check if this is an appropriate pump type:
 - Model type and design
 - Direction of rotation and position of the suction/pressure side
 - Temperature range

ATTENTION!

If you detect differences between the pump design you require and the one supplied by us, please contact us immediately.



- *Do not commission the pump without request.*
- *Only attach the pump/pump units using the holes provided. The installation space must be level. Compensate for unevenness near the connection points with appropriate support pads which results in an even level over these four connection points. If strong oscillations/vibrations should occur during operation of the pump, please observe the points listed in the fault table(⇒ Chapter "[Fault](#)"³⁶).*

It is important that the drive rotation direction set, enables the correct transport direction. Reversing the rotation direction also results in a reversal of the transport direction.

Significant damages to the system and danger for the attending personnel can occur if the pump is run in the wrong rotation direction.

A drop test as defined in DIN EN 13 463-1, section 13.3.2.1 was not carried out. Protect the pump against vibrations and shocks. Vibrations or shocks could have an influence on the function. Ground the gear pump (⇒ Chapter "Danger from Potential Difference").

5.3 Installation Position



ATTENTION!

The pump can be installed horizontally and vertically.

In the case of vertical installation, it is preferable to place the motor above the pump head. With vertical alignment, increased noise emission must be expected.

5.4 Connection Pipes

- Check if the connection flanges of the pipes correspond to those of the pump, prior to connecting the suction and pressure pipes.



WARNING!

Do not exert pressure or forces on the pump via the connection pipes, a connection pipe support may be required before each pump. Furthermore, any impact through forces induced by thermal expansion on the pump is prohibited.

The connection pipes must be adequately dimensioned. They must not be chosen smaller than the nominal width of the pump connections. On the suction side, we recommend a nominal width one size bigger than the nominal width of the pump's suction connection.

The following guideline values apply as max. flow speed values in the pipes:

For recommended flow speed, see table.

	up to 200 mPas	up to 600 mPas	up to 2000 mPas
Suction pipe	1.5 m/s	0.5 m/s	0.2 m/s
Pressure pipe	3.0 m/s	1.0 m/s	0.5 m/s

ATTENTION!



- **Position a suction filter with at least a 20µm, $\beta=200$ filter mesh upstream of the pump, in order to avoid premature wear or damages caused by the ingress of foreign matter that can lead to the destruction of the pump. Select a sufficient size for the filter because of its interior resistance it can otherwise affect the suction performance of the pump.**
- **Use the largest possible radius for necessary curves in the pipe routing. Avoid sharp-angled elbows, if possible.**
- **Lay the suction pipe rising up to the pump. If pipes must be laid rising and falling, integrate vents at the highest points.**
- **After laying, check the pipes for deposits, chips or other dirt as otherwise the pump can be damaged when being commissioned.**

Note that all pipes, fittings and screw connections must be perfectly sealed, otherwise gas can enter into the pipe on the suction side. The pump does not suck in any more. Fluid can escape on the pressure side.

If a suction height of 3 m is reached, we recommend the installation of a foot valve in the suction pipe. When switching off the pump, the valve ensures that no reverse fluid flows through the pipe or no emptying of the suction pipe occurs.

Please note that in the case of an installation situation in which the pump is idle, the pressure at the inlet is equal to the pressure at the outlet. Please note the max. system pressures(⇒ chapter "[Limit Values](#)"¹³).

6 Commissioning/Decommissioning

6.1 Requirement for Commissioning

- After the complete installation of the pump and the peripheral equipment, check them once again according to the following points:
 - Have you connected the suction and pressure side correctly?
 - Are sliders, flaps and valves in the system in the right position?
 - Has the piping system been checked for leakages?
 - Is it possible to shut down the pump with the emergency stop in case of an unrecognized or unforeseeable malfunction that may arise during the first powering of the machine?
 - Is the fluid filled into the container sufficient and correct?
 - Temper the pump prior to commissioning when the temperature difference between the pump and the fluid is greater than 50°C!



Installation work must only be carried out when the drive unit is switched off.

6.2 Commissioning

- Disinfect the pump head and the pipes if necessary.
- In order to avoid contamination of the fluid, flush pipes for at least five minutes with the desired fluid and accordingly selected speed to remove any test fluid residuals from the pump head.
- The dry cycle time of the pump head should not exceed 30 seconds as longer dry cycle times present the risk of destroying the pump.

6.3 Decommissioning

CAUTION!

- **Completely empty the pump head by reducing the counter-pressure to 0 bar and, if possible, remove the suction pipe from the reservoir so that the ambient air can be sucked in.**

Do not decommission when a system pressure, a vacuum or reacting fluids are present.

- ***Take care that the dry cycle time does not exceed 30 seconds, as the pump can be destroyed otherwise.***
 - ***When fluids that present a health risk have been transported, flush the pump head several minutes with an appropriate cleaning or neutralization agent.***
 - ***Finally, the pump head must be flushed once again with water.***
 - ***Close the shut-off valve (if present) before and after the pump. Close the shut-off devices only if the pump is idle for a long time (in automatic plants only if the entire plant is decommissioned).***
-



6.4 Removal from the System

ATTENTION!

Switch off the drive unit! Take care that the working steps described in (⇒ chapter "[Decommissioning](#)"³²) have already been performed.

Remove the connection pipes.

7 Maintenance/Cleaning

7.1 General Information

For maintenance purposes, you must ensure that the pump was flushed with harmless fluids. If the pump was operated with fluids hazardous to health, the maintenance must be carried out with respective protection measures (⇒ [chapter "Safety Instructions"²³](#)).

When shipping the pump, completely fill in the certificate of non-objection attached. Pumps are not repaired without a certificate of non-objection.

7.2 Safety Instructions for Maintenance, Inspection and Installation work

DANGER!

You, the operator, are responsible that any maintenance and installation work is performed by authorized and specialist personnel who are sufficiently informed after having carefully read the operating instructions.



- *As a basic principle, all work must only be carried out with the pump stopped.*
- *Prior to any installation and maintenance work, the motor must be de-energized.*
- *Pumps or pump aggregates distributing fluids hazardous to health must be decontaminated.*
- *Personal protective equipment must be worn (⇒ [chapter "Personal Protective Equipment"⁹](#)).*
- *Directly after having carried out the work, all safety and protection devices must be re-mounted and put into operation again.*
- *Before commissioning, the points listed in the (⇒ [chapter "Commissioning/Decommissioning"³²](#)) must be observed.*

7.3 Maintenance Cycle

The pump is not subject to regular maintenance cycles.

Cleaning/maintenance is necessary when:

- the pump is stored,
- the pump is decommissioned for a long time,
- the pump no longer meets the basic data shown in the chapter Technical data (= chapter "[Technical Data](#)"^{□38}),
- another fluid is transported,
- leakages occur on the pump.

Observe also the transport notes (= chapter "[Transport and Interim Storage](#)"^{□26}) and the troubleshooting (= chapter "[Faults, Causes and Rectification](#)"^{□36}).

ATTENTION!

Observe that all O-rings must be replaced during re-assembly in case of any maintenance work including the dismantling of the pump. Otherwise, complete leakage safety cannot be guaranteed.

It is also important to keep the workplace absolutely clean, as dirt can endanger the proper function of the pump.

7.4 External Cleaning of the Pump



DANGER!

When cleaning the outside of the pump, it must be ensured that the cleaning process is compatible with the IP protection class of the pump motor unit. In addition, no cleaning media that corrode or damage the surface of the product may be used.

7.5 Cleaning of the Pump for Use in Special Areas



CAUTION!

When using the pump for distributing food or in the pharmaceutical and/or cosmetics sector, observe the currently valid hygiene rules when using cleaning agents, disinfectants or flushing agents.

- *Make sure that the fluids to be distributed are not contaminated with residual cleaning or flushing agents and/or disinfectants.*

The manufacturer recommends only using liquids for cleaning, disinfecting and/or flushing, that do not affect the fluid in case of a contamination.

If this is not possible, measures have to be taken in order to guarantee a complete removal of cleaning or flushing agents and/or disinfectants prior to re-commissioning.

8 Faults, Causes and Rectification

Number	Fault type
1	The pump does not suck in.
2	The pump builds up too little pressure or none at all.
3	The pump makes noise.
4	The pump heats up.
5	The pump operates loudly and/or vibrates/oscillates greatly.
6	The pump is blocked.

Fault						Cause and rectification of the fault
1	2	3	4	5	6	
x			x			<p>The pump runs dry</p> <p>There is no fluid in the suction pipe or the suction height is greater than 3 m. Operation without fluid lasting more than 30s can destroy the pump and should therefore be avoided.</p> <p>The pumps of this series can suck in fluid at a distance of 3m when dry. However, the suction performance can be further improved when the pump is filled with fluid before commissioning.</p>
x						<p>Pipework incorrectly laid</p> <p>Incorrectly dimensioned pipes can have a very negative effect on the suction performance of the pump. Observe the general information in (⇒ chapter "Connection Pipes" 30).</p>
x						<p>Pressure/suction pipe closed</p> <p>If there is a shut-off valve integrated into the pressure or suction side, make sure that this is open. If there is still air in the pressure pipe, make sure that it can escape.</p>
x	x			x		<p>Pump components worn</p> <p>If the pump does not suck in any more at the same operating conditions and the suction as well as the pressure pipe are not closed, it is possible that the pump has to be repaired.</p>
x						<p>Suction pipe is leaking</p> <p>Make sure that the suction pipe is absolutely gas-tight so that the ambient atmosphere cannot be sucked in.</p>
x						<p>Connection pipe incorrect</p> <p>Check if the suction and pressure pipes are interchanged.</p>
x	x				x	<p>Foreign matter, soiling and/or deposits may be blocking the pump.</p> <p>These can normally only be analyzed/rectified by dismantling the pump (⇒ chapter "Pump Body").</p>
x						<p>Check motor connection</p> <p>The motor may be incorrectly polarized. See the motor manufacturer's operating instructions.</p>
x						<p>Incorrect direction of rotation of the pump</p> <p>See direction of rotation on the type plate of the pump.</p>

Fault						Cause and rectification of the fault
1	2	3	4	5	6	
x	x					<p>Pipe closed</p> <p>If there are shut-off valves in the pipe on the pressure or the suction side, make sure that they are open.</p>
x	x	x				<p>Magnetic coupling uncoupled</p> <p>The uncoupling of the magnetic coupling is accompanied by a rattling sound. The magnetic coupling serves amongst other things as overload protection (⇒ chapter "Installation of the Magnetic Coupling"). In order to uncouple the magnetic coupling, an operating condition must be present that (at least for a short time) was above the pump specification value. Stop the drive and restart the pump. If the fault occurs again, rectify the causes. Possible causes can be:</p> <ul style="list-style-type: none"> - differential pressure too high - fluid viscosity too high - dirt in the pump
	x					<p>Fluid viscosity too low</p> <p>The hydraulic efficiency of the pump depends on the viscosity of the fluid. If the viscosity (induced by the fluid or too high temperatures) decreases too much, this can lead to the decrease of the output rate.</p> <p>Compare the current viscosity and temperature with the initial viscosity and temperature during the laying of the pipes and correct them if necessary (⇒ chapter "Limit Values" ¹³)</p>
		x				<p>Operation in cavitation</p> <p>Due to an inadmissibly low inlet pressure (absolute) or inadmissibly high suction height, steam bubbles occur, depending on the vapor pressure of the fluid, in the suction zone of the pump. They implode on the pressure side and lead to the increased wear of the pump. This operating point can be avoided by changing the feeding conditions. Audible through a singing noise.</p> <p>Increase the inlet pressure by reducing the pipe resistance. Decrease the fluid temperature.</p>
			x			<p>Normal operation</p> <p>Please check first if this is not a normal heating caused by the fluid to be transported. The pump surface shortly reaches the same temperature as the fluid.</p>
		x				<p>Component wear</p> <p>If you can hear a grinding noise, the cause might be wear in the pump. The pump cannot be further operated in this condition. Immediately stop the drive. The repair or replacement of the pump is mandatory.</p>
				x		<p>Unfavorable installation conditions</p> <p>Significant oscillations and vibrations do not occur in normal operation mode. Individually, and dependent on the installation conditions, oscillations and vibrations can be reduced by the following measures:</p> <ul style="list-style-type: none"> - Put vibration-damping supports underneath the motor. - Fix the connection pipes with oscillation-damping elements.

9 Technical Data

Note: Special pump designs may deviate from the following dimensions.

9.1 Connection Dimensions 2876.00 / 2876.02

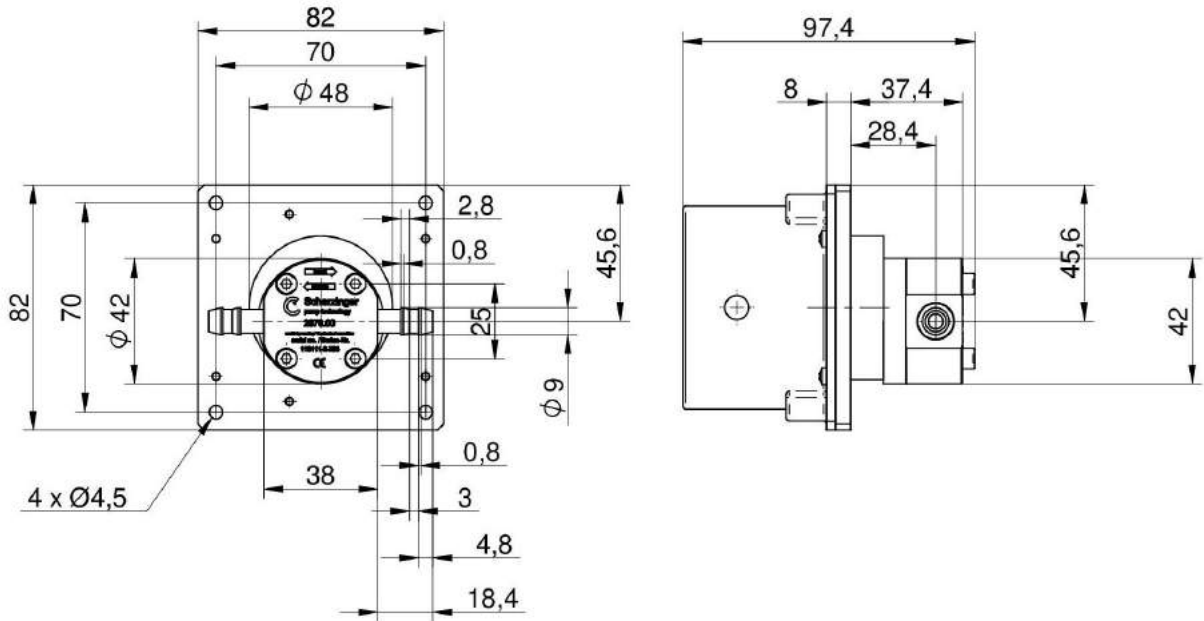

9.2 Connection Dimensions 2876.01 / 2876.03

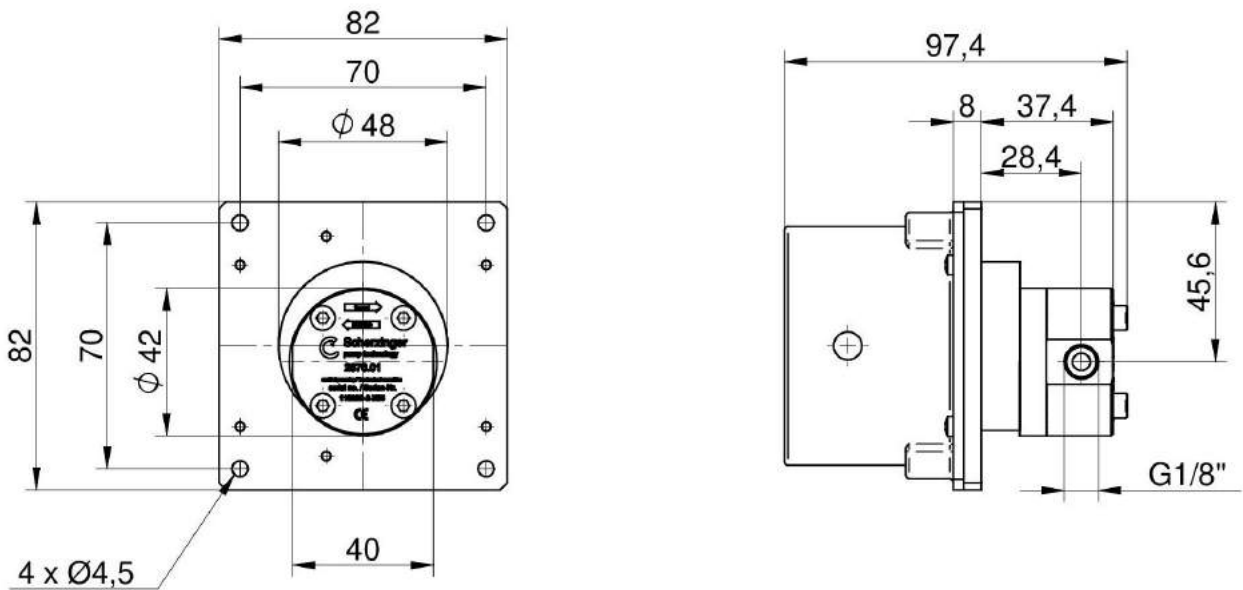

9.3 Sound Pressure Level

The sound pressure level measurement was performed under the following conditions:

Distance between the sensor and the pump: 1m

The sound pressure level of the pump is below 70 dB(A) for all operating points.

Information about the sound pressure level:

- The pump measurement is taken when decoupled, on rubber feet and with hose elements to attenuate the suction and pressure line.
- In the event of pump cavitation (e.g. suction line too small) and/or structure-borne sound due to vibrations in the entire system (pump/system), the above value may be exceeded by up to 10 dB(A).

9.4 Non-ionizing Radiation



DANGER!

A non-ionizing radiation emanates from the pump with magnetic coupling in the form of a magnetic field. This can destroy products that are sensitive to magnets.

These products include among other things:

- *implanted medical devices (e.g. pacemakers),*
 - *credit cards,*
 - *electrical, electronic and fine mechanical devices (e.g. hard drives).*
-

10 Disposal

The pump can be dismantled into its constituent components and recycled, according to what materials were used, after a correct decommissioning (=**chapter "Decommissioning"**) and after removal of the fluid and elimination of any residual lubricants.



CAUTION!

You have to dispose of the pump, pump accessories and fluids in accordance with the currently valid and nationally applicable regulations.

Pump components can be contaminated with toxic or radioactive fluids. Prior to the disposal of these components, you must clean them with the appropriate flushing/cleaning agents. The flushing/cleaning agent must be adapted to the fluid last transported by the pump to rule out a hazardous chemical reaction between the transported fluid and the flushing/cleaning agent. Wear appropriate protective equipment.

The pump manufacturer is not to be held liable for the disposal.

10.1 Disposal of the Fluid

The fluid must be disposed of in an environmentally friendly manner and in accordance with regional and national regulations.

- Make sure the fluid is not released into the environment.
- Dispose of the fluid in suitable containers in accordance with the regulations.

11 Appendix

11.1 List of Revisions

Revision no.	Description	Date	Author	Approved

11.2 Signature List

Procedure/completing the signature list

- Make a copy of the following signature list.
- Enter the name of your company/authority and use your company stamp to confirm.
- Make sure that every employee who works with this product signs this list to confirm that he/she has read and understood the operating instructions. Persons who do not provide their signature as confirmation are not authorized to work with this product!
- Then archive this list in your files.

Signature list

of the company/the operator:

Address/stamp

By providing their signature, the persons listed hereinafter confirm that they have received instruction on the basis of the operating instructions in

- the function,
- operation,
- maintenance, cleaning
- and installation

of the product (Pump) and that they have read and understood the safety instructions of the operating instructions.

Participant Last name, first name	Date Signature	Instructor Last name, first name Date, signature

This page has been left blank on purpose.



Address:

Scherzinger Pumpen GmbH & Co. KG
Bregstraße 23 - 25
78120 Furtwangen / Deutschland

Postal address:

Scherzinger Pumpen GmbH & Co. KG
Postfach 11 54
78120 Furtwangen / Deutschland

Communication:

Telefon: +49 7723 6506-0
E-mail: info@scherzinger.de
Internet: www.scherzinger.de